



Small capacity buffer tank

BT-HP

30 | 50 | 80 | 100 litre



Small and

POWERFUL

NEW!

Small capacity buffer tank

BT-HP 30 | 50 | 80 | 100 litre

Small and powerful. Small capacity buffer tanks fit almost everywhere due to their small size. A particular advantage is that installation can be wall-mounted or floor-standing.

BENEFITS

- installation wall-mounted or floorstanding
- full range in one design
- Ensuring the minimum flow rate
- Energy for defrosting
- More efficient DHW heating in summer during cooling
- Longer service life of the heat pump by reducing the cycle time



Pufferspeicher

BT-HP 30 | 50 | 80 | 100 Liter

SPECIFICATIONS:

- ERP B
- 4x 6/4" connections for 30 to 100 L
- Manual venting factory equipped
- Sensor pocket for temperature sensor



Technical data

BT-HP 30 | 50 | 80 | 100 litre

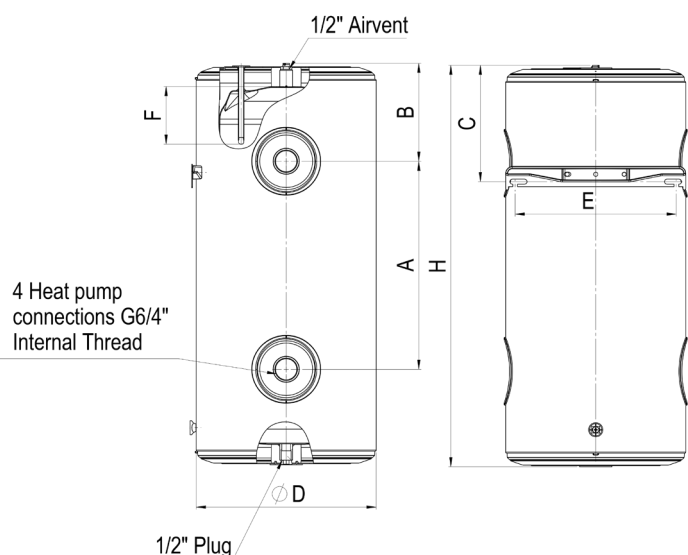

30-50 litre

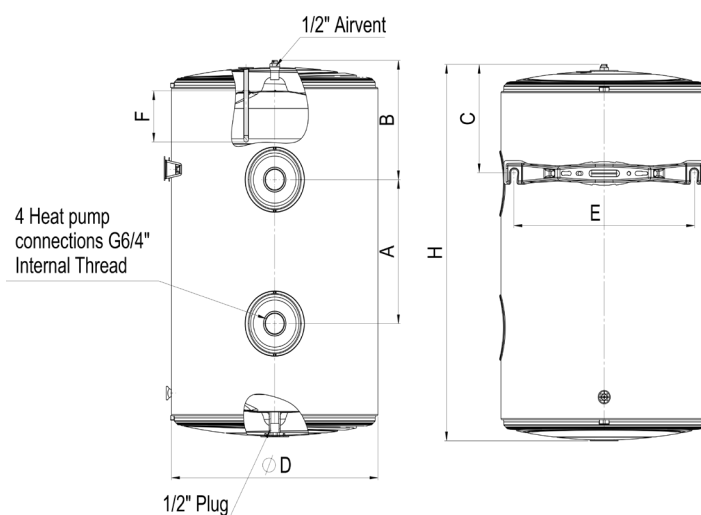

80-100 litre

Type		BT-HP 30	BT-HP 50	BT-HP 80	BT-HP 100
Article no.		A 344 89	A 344 90	A 344 91	A 344 92
Dimension (A)	mm	156	443	319	481
Dimension (B)	mm	201	201	249	249
Dimension (C)	mm	169	241	226	267
Dimension (D)	mm	392	392	523	523
Dimension (E)	mm	340	340	440	440
Dimension (F)	mm	10	10	10	10
Dimension (H)	mm	568	855	832	994
Operating pressure	bar	max. 3			
Insulation		PU foam thermal insulation			
Weight / pc.	kg	11,4	14,8	21,5	25,3
Min. order quantity		18 pcs / 1 pallet	12 pcs / 1 pallet	8 pcs / 1 pallet	8 pcs / 1 pallet
Heat loss	W	32	39	42	47
Energy efficiency class		B	B	B	B

Head office: Austria Email AG,
Austriastraße 6, 8720 Knittelfeld
Tel. (03512) 700-0
E-Mail: office@austria-email.at
Internet: www.austria-email.com

