

Upright water heater (10 bar)

HT ER

120 LITRES

“

Achieves label B due to the 50 mm insulation!

”



UPRIGHT WATER HEATER

TECHNICAL DATA

- Operating pressure 10 bar
- Capacity: 120 L
- Energy-saving PU foam insulation
- Smooth-tube heat exchanger with particularly large heating surfaces
- Hot water outlet to the top guaranteed complete ventilation
- Adjustable support feet
- Blind flange (D 180 mm, DN 110) and Flange insulation bonnet factory-fitted
- Sensor positioning by means of immersion tube

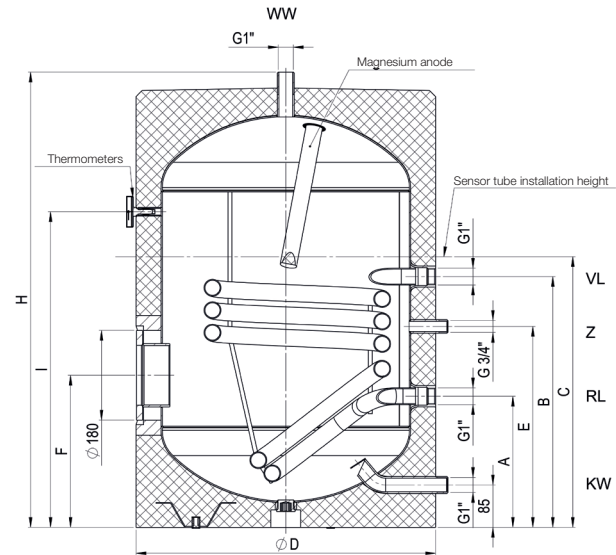

ACCESSORIES

- Height-adjustable feet included
- Flange heating \varnothing 180 mm
- Safety and non-return valve DL-SVRV
- External current anode (retrofit kit)
- Finned tube heat exchanger

ECO DESIGN LABELING

7 YEARS WARRANTY ON THE INNER BOILER

Type	Heat loss according to EN 12897		Tapping profile	Energy efficiency class
	in kWh/24h	S in watt		
HT 120 ER	1,24	51,7	L	B

TECHNICAL DATA

Type	Article no.	Dimensions in mm								Anode in mm	Heat exchanger surface m ²	Tilt-dimension in mm	FID in mm	Weight in kg
		D \varnothing	A	B	C	E	F	H	I					
HT 120 ER	A 288 13	600	263	503	543	403	305	913	633	\varnothing 33x300	0,57	1100	400	70

FID: Flange installation depth (for built-in heating or finned tube heat exchanger)